

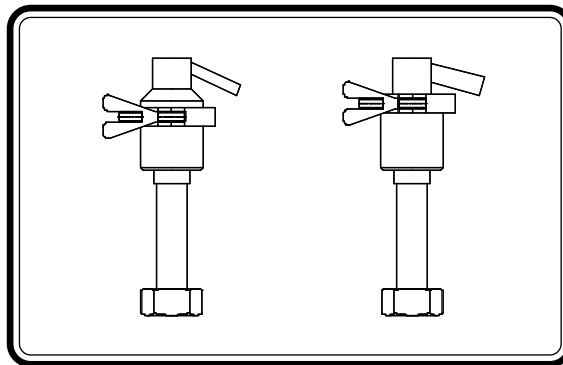

# INSTRUCTION MANUAL

## Vent Valve models

AE AP



Model	
Serial no. <sup>1</sup>	
Data sheet	

1) Please quote the serial number when ordering spares.

Manufactured by: **MDM PUMPS LTD**  
Spring Lane  
Malvern  
Worcs WR14 1BP  
England

Tel: +44 (0)1684 892678  
Fax: +44 (0)1684 892841  
E-mail: [info@mdmpumps.co.uk](mailto:info@mdmpumps.co.uk)  
[www.mdmpumps.co.uk](http://www.mdmpumps.co.uk)



*This page is intentionally blank.*

## Introduction

Thank you for purchasing the MDM PUMPS LTD stainless steel vent valve.

This instruction manual describes how to install, assemble, maintain, repair and dismantle your vent valve.

**Please retain it safely for future reference.**

## Application

The vent valve should only be used for the conditions as specified in the data sheet, ie duty and liquid details. In addition it has been designed for use with industry recognised cleaning solutions.

Unless otherwise stated in the data sheet, the maximum allowable working pressure is 4.6 bar (the vent valve is hydrostatically pressure tested to 1.5 times this value).

## Safety

Safety instructions given in this manual noncompliance with which would affect safety are identified by the following symbol:



## Design & Function

There are two types of vent valve available:

AE - "Air Escape". This allows air to escape, but not to re-enter. It is typically used on pipework for scavenging applications.

AP - "Air Pass". This allows air to escape and to re-enter. It is typically used for tank filling or syphon breaking.

## Dimensions

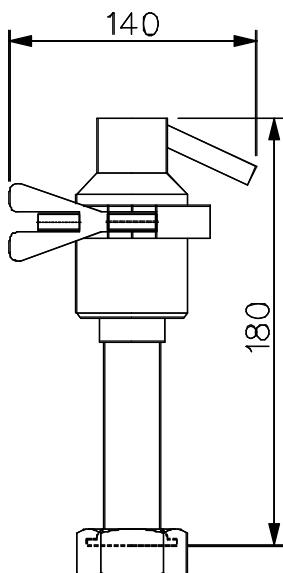

This diagram shows the approximate overall dimensions. If you require more detailed information, please contact MDM PUMPS LTD.

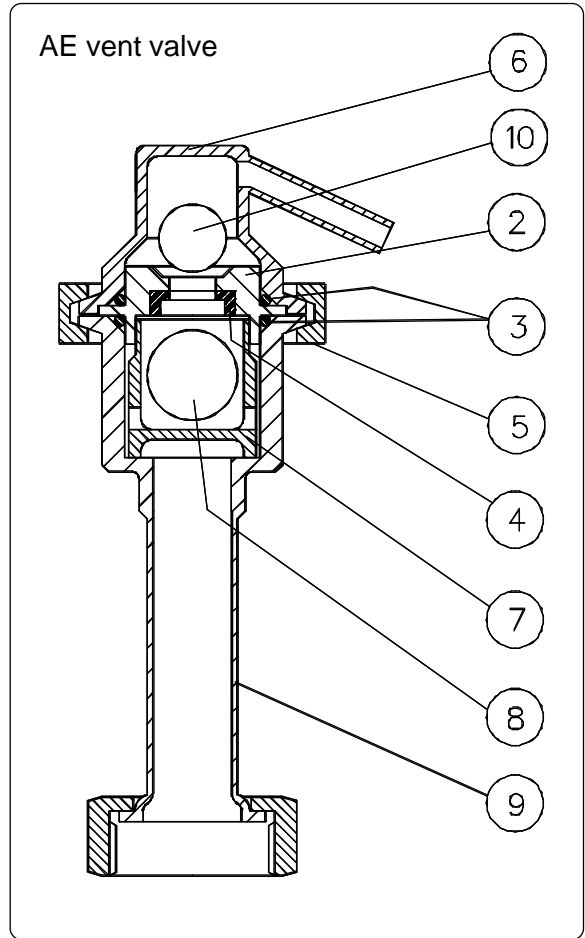
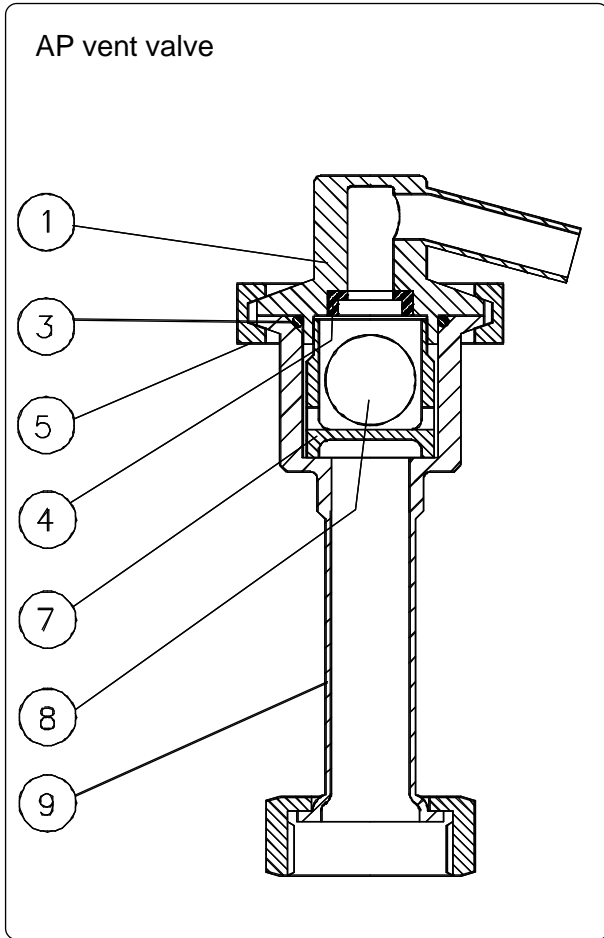

Item	Description
1	AP vent valve lid
2	Seat housing
3	Body joint ring
4	Float seat ring
5	Clamp ring
6	AE vent valve lid
7	Float basket
8	Float
9	Body
10	Ball

## Installation

Before installation check that the vent valve is in good condition and that there are no signs of damage or deterioration.

- 1) Connect the vent valve so that it is mounted vertically. Ensure that the connection is sufficiently tight to prevent ingress of air.
- 2) Ensure that the clamp ring is tight and that the outlet tube is pointing in a safe direction.

## Operation



- Warnings:
- Ensure that the vent valve is correctly installed before operation.
  - If the lid and the inlet/outlet connections are not correctly fitted, there is a risk of contact with the fluid and of the fluid being ejected.
  - Do not exceed the maximum allowable working pressure of the vent valve.
  - Wear the appropriate personal protection equipment.

## Cleaning

The vent valve should be regularly cleaned. The type of cleaning chemicals to be used, their concentration, temperature and period of contact will be determined by:

- a) The product.
- b) The level of contamination.
- c) The method of cleaning.
- d) Compatibility with the materials inside the vent valve:
  - SS316L
  - Seal and ball materials (see the data sheet).

The vent valve generally forms part of a system which is cleaned in place (CIP). Where this is not possible, the wetted parts of the vent valve can be dismantled, soaked in a detergent/disinfectant bath, rinsed in clean water and reassembled.



When hazardous chemicals are handled, the appropriate personal protection equipment should be worn.

## Spare Parts

The following parts may need replacing during the lifetime of the vent valve:

LINE	PART	AVERAGE EXPECTED LIFE	SIGNS OF FAILURE
1 <sup>st</sup>	Body Joint Ring	2 years *	Leaking from around the clamp ring.
1 <sup>st</sup>	Float Seat Ring	2 years *	Leaking from around the outlet connection.
1 <sup>st</sup>	Inlet Joint Ring	2 years *	Leaking from around the inlet connection.
1 <sup>st</sup>	Float	3 years *	Leaking from around the outlet connection.
1 <sup>st</sup>	Ball (AE only)	3 years *	Air re-entering through the outlet connection.

Note: \* The average expected lives are subject to the full service conditions being disclosed, the seals being appropriately selected and approved parts being used.

## Monitoring

Monthly: Check the vent valve for leaks.

## Dismantling the Vent Valve

If the vent valve is in contact with hazardous liquids, then it must be decontaminated before dismantling. The appropriate personal protection equipment should be used.

- 1) Disconnect the vent valve.



Risk of contact with liquid.

- 2) Unscrew the clamp ring handle by several turns and lift the clamp ring off the vent valve body.

- 3) AE vent valve: Remove the lid, the ball and the seat housing. The ball, seals and float are now exposed and can be cleaned and inspected.

AP vent valve: Remove the lid. The seals and float are now exposed and can be cleaned and inspected.

## Reassembling the Vent Valve

Please refer to page A3 for the assembly drawing.

## Faults - causes & remedies

This section lists the common faults. For further advice please contact MDM PUMPS LTD or your supplier. Note: the vent valve has been checked for leaks and performance tested with water.

PROBLEM	CAUSE	REMEDY
1) Leaking body joint ring.	Clamp ring not located correctly. Incorrectly fitted seal. Damaged seal. Violent pressure fluctuations in the system.	Ensure that the clamp ring is correctly located and is tight. Check that the seal is correctly fitted and is clean. Replace the seal. Reduce the violent pressure fluctuations.
2) Leaking float or float seat ring.	Incorrectly fitted float or float seat ring. Damaged float or float seat ring. Contamination with soil.	Check that the float and float seat ring are correctly fitted. Replace the float and float seat ring. Clean the float and float seat ring.
3) Air re-entering through the outlet connection (AE only).	Incorrectly fitted ball. Damaged ball. Contamination with soil.	Check that the ball is correctly fitted. Replace the ball. Clean the ball.



Manufacturers of Stainless Steel Pumps,  
Vent Valves & Strainers for hygienic applications

Founded in 1922, MDM PUMPS LTD is registered to BS EN ISO 9001

**MDM PUMPS LTD**

Spring Lane  
Malvern  
Worcs WR14 1BP  
England

*Tel:* +44 (0)1684 892678

*Fax:* +44 (0)1684 892841

*E-mail:* [info@mdmpumps.co.uk](mailto:info@mdmpumps.co.uk)

[www.mdmpumps.co.uk](http://www.mdmpumps.co.uk)