



### Introduction

The 'D' range pumps manufactured prior to 1994 were fitted with a pump stub shaft which was heat shrunk onto the motor shaft and then pinned. Since 1994, the pump stub shaft has been clamped onto the motor shaft. This makes maintenance easier and avoids the problems that can arise from heating the shaft and re-pinning it.

These instructions describe how to modify pumps fitted with pinned pump stub shafts (manufactured prior to 1994) and convert them to shaft clamp types.

Considerations:

- The motor shaft must be clean and in good condition (ie not filed, fretted or tapered) and its diameter must be within the motor manufacturers limits (see the table on page P2).
- You will need a new pump stub shaft (shaft clamp type), shaft clamp and motor shaft oil seal. Consider fitting a new mechanical seal.
- For D3 & D4 pumps fitted to motor frames 160 and above, and for D4A, D5, D5A, D6 & D6A pumps you will need a new shaft guard.
- The flanged adaptor will need modifying in a lathe (see pages P2 & P3).
- The housing plate on D5, D5A, D6 & D6A pumps will need modifying in a lathe (see page P3).

### Dismantling the Pump



Pumps which convey hazardous liquids must be decontaminated before dismantling the pump. The appropriate personal protection equipment should be used.

These instructions are general instructions. For detailed instructions on changing the seal(s) and stubshaft in a specific pump, please contact MDM PUMPS LTD.



The pump stub shaft boss needs to be heated with a gas blow lamp. The appropriate personal protection equipment should be used, and the hot items should be treated with care.

ATTENTION

The motor shaft oil seal can become damaged during pump stub shaft removal. It is therefore recommended that this is replaced once the shaft has been removed (please refer to the motor manufacturer's instructions).

*Tools required: Open ended spanner, across flats - 11mm (D2, D2W with seal flush only), 15mm (D2), 22mm (D2W), 17mm & 1 1/8" (D3, D4), 24mm (D4A, D5, D6), 33mm (D4A, D5, D6), 46mm (D5A, D6A), 2 Steel levers, Motor shaft oil seal, Dial test indicator, Pin punch, diameters - 6mm (D3, D4), 8mm (D4A, D5, D5A, D6, D6A), 3/16" (D2/D2W), Engineers pliers, Screwdriver - medium flat blade, Hide mallet, Gas blow lamp, Torque wrenches - 0 to 20 Nm for the shaft clamp & as required for the locknut, Allen key, across flats - 6mm, 10mm (D5, D5A), 3/16" (D2/D2W single internal seal).*



1) Isolate the motor (1) from the power supply.

2) Disconnect the inlet and outlet connections.



Risk of contact with liquid being pumped.

3) Unscrew the clamp ring handle(s) (8) by several turns and lift the clamp ring (7) over the flanged adaptor (5).

4) Remove the cover (18).

5) Unscrew the impeller locknut (22) with the spanner (right hand thread).

6) Slide the impeller vane plate (20) and (where fitted) the back plate (19) forward off the shaft (14) by maintaining an even pressure. Hitting the impeller can cause serious damage.

7) Remove the key (21) from the pump stub shaft (14).

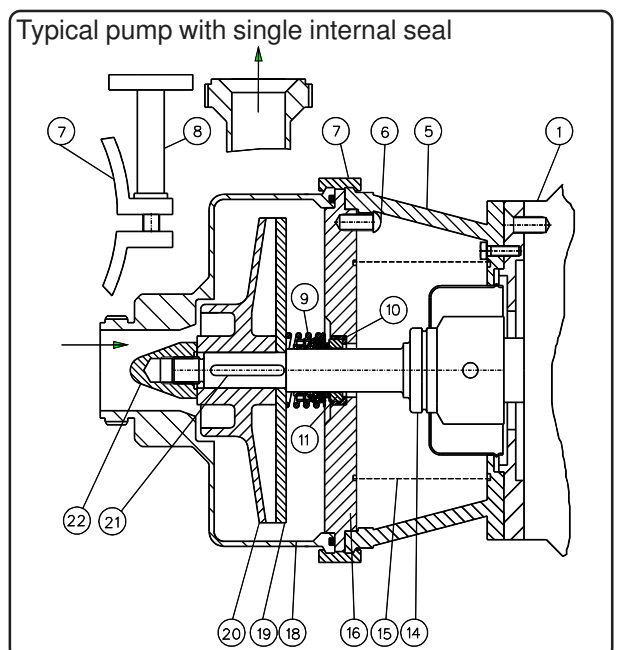

- 8) The mechanical seal (9) is now accessible. Slacken the seal grub screws (where applicable), clean the shaft and slide the seal forwards off the shaft.
- 9) Unscrew the housing plate screws (where applicable) (6) and take out the housing plate (16).
- 10) Remove the flanged adaptor (5).
- 11) Remove the spirol pin(s) from the boss of the pump stub shaft (14).
- 12) To remove the pump stub shaft, heat the boss of the pump stub shaft (14) with the blow lamp to expand the bore and break the Loctite bond (the pump stub shaft is a shrink fit onto the motor shaft and may have been fitted with loctite).
- 13) Use the steel levers (21) to remove the pump stub shaft (14).
- 14) Measure the motor shaft diameter to ensure that it is within the motor manufacturer's limits (see table right). The motor shaft must be clean and in good condition (ie not filed, fretted or tapered) - please contact MDM Pumps for advice if it is not in good condition.
- 15) Replace the motor shaft oil seal which can become damaged during pump stub shaft removal (see the motor manufacturer's instructions).

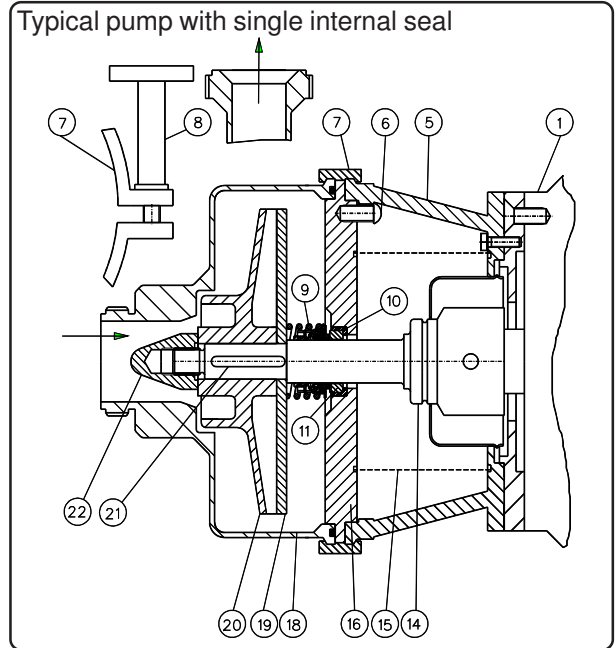

Motor frame size	Motor shaft diameter (mm)	Motor shaft diameter limits (mm)
71	14	+0.008 / -0.003
80	19	+0.009 / -0.004
90	24	+0.009 / -0.004
100/112	28	+0.009 / -0.004
132	38	+0.018 / +0.002
160	42	+0.018 / +0.002
180	48	+0.018 / +0.002
200	55	+0.030 / +0.011
225/250	60	+0.030 / +0.011

## Modifying the parts

The following modifications are required to ensure that the shaft clamp and new pump stub shaft will fit:

### D2, D2W

The flanged adaptor (5) needs a  $\text{Ø}77\text{mm}$  recess machined in it - see figure 1.

The D2 original dimension was typically  $\text{Ø}34\text{mm}$  or  $\text{Ø}39\text{mm}$

The D2W original dimension was typically  $\text{Ø}46\text{mm}$  or  $\text{Ø}53\text{mm}$ .

Figure 1: D2, D2W flanged adaptor modifications

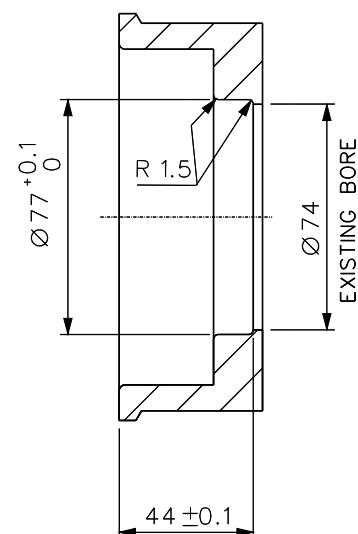

### D3, D4 (for D4A see section below)

- The flanged adaptor (5) needs an internal diameter to be machined from  $\text{Ø}100\text{mm}$  to  $\text{Ø}110\text{mm}$  - see figure 2.
- For pumps fitted to motor frames 132 and below, the hose guard and shaft guard can be refitted.

For pumps fitted to motor frames 160 and above, the hose guard is discarded and the shaft guard (15) must be replaced with a new type.

Figure 2: D3, D4 flanged adaptor modifications

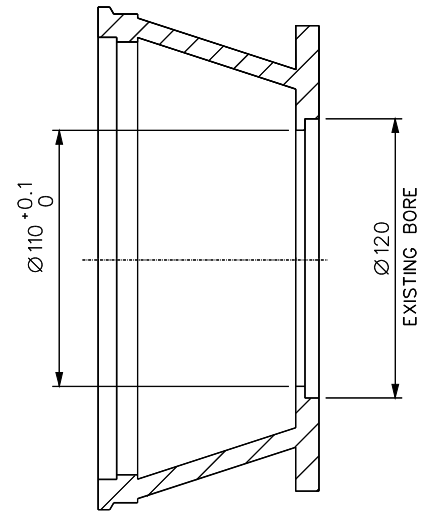

### D4A

- The flanged adaptor (5) needs an internal diameter to be machined from  $\text{Ø}112\text{mm}$  to  $\text{Ø}155\text{mm}$  - see figure 3.
- The hose guard (where fitted) is discarded and the shaft guard (15) must be replaced with a new type.

### D5, D5A, D6, D6A

- The flanged adaptor (5) needs an internal diameter to be machined from  $\text{Ø}112\text{mm}$  to  $\text{Ø}155\text{mm}$  - see figure 3.
- The housing plate (16) needs a larger diameter groove ( $\text{Ø}155\text{mm}$  external diameter) machined in it - see figure 4.
- The hose guard (where fitted) is discarded and the shaft guard (15) must be replaced with a new type.

Figure 3: D4A, D5, D5A, D6, D6A flanged adaptor modifications

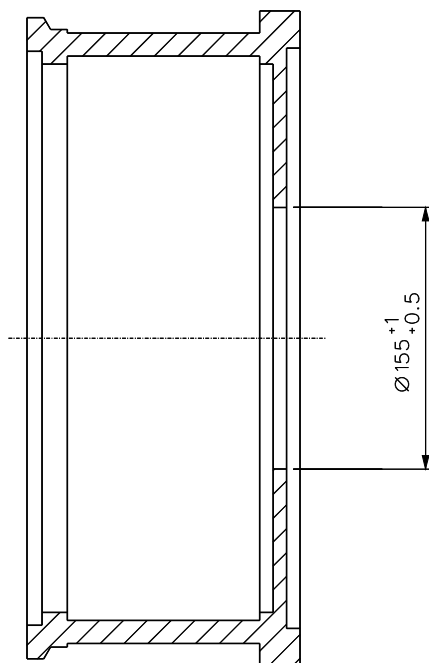
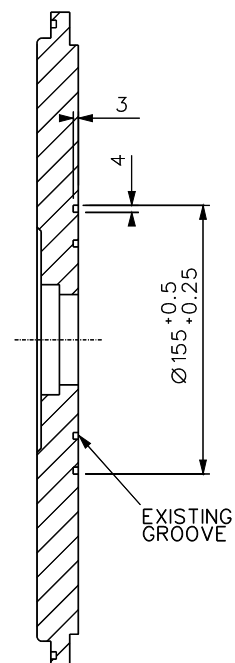

Figure 4: D5, D5A, D6, D6A housing plate modifications



## Replacing the Pump Stub Shaft

**ATTENTION**

The locking screws in the Shaft Clamp (2) must not be completely unscrewed, as they are pretensioned and could jump apart.

Do not tighten the screws (4) until the Shaft Clamp is positioned on the pump stub shaft (3).

Oil or grease containing MoS<sub>2</sub> should not be used.

- 1) Ensure that the surface of the motor shaft (6) is clean and free from oil or grease.
- 2) Slide the pump stub shaft (3) onto the motor shaft.
- 3) Position the Shaft Clamp between the two witness lines (7) on the pump stub shaft.
- 4) Ensure that the pump stub shaft is pushed fully home on to the motor shaft **before** tightening the locking screws (4), otherwise deformation may occur. Refit the flanged adaptor (1) to check dimension "A", see table.

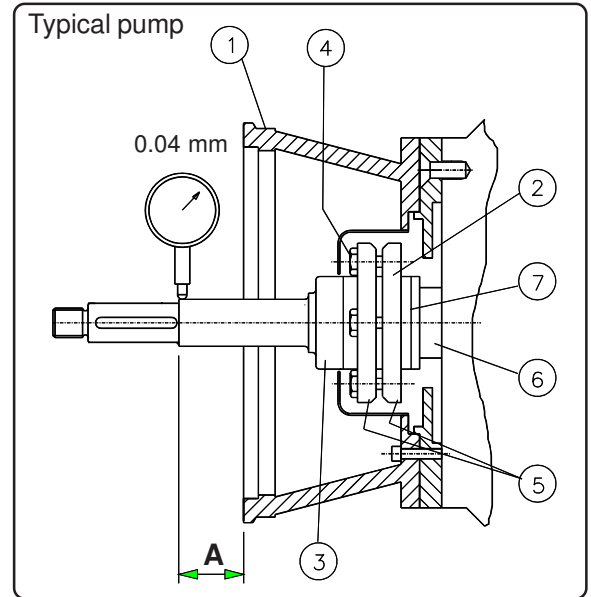

Pump model	D2/D2W	D3/D4	D4A	D5/D5A	D6/D6A
Dim "A" (mm)	33	35	30	59	59

- 5) Remove the flanged adaptor (1) and tighten the locking screws (4) finger tight to squarely position the thrust rings (5).
- 6) Tighten the locking screws (4) in a clockwise sequence (where hexagonal bolts are fitted) or in a diametrically opposite sequence (where socket head cap screws are fitted). Tighten in two stages: up to half full torque, and then up to full torque (see table below).

Motor shaft diameter (mm)	Stub shaft boss diameter (mm)	Full torque (Nm)
14	20	14.0
19	30	3.0
24 - 38	36 - 50	6.5
42 - 55	55 - 68	7.0
60	75	15.0

Finally, repeat the tightening of the locking screws until all screws are tightened to the full torque.

- 7) Clock the shaft for true running (Total Indicator Reading - ie total tolerance 0.04mm) and finally refit the flanged adaptor (1) and hose guard (where applicable) and re-check dimension "A".

## Reassembling the Pump

- 1) Locate the seal seat assembly (10,11) in the housing plate (16) (The seal seat (11) and seat ring (10) should both be inspected and replaced if necessary). Fit the housing plate into the flanged adaptor (5) and where applicable, tighten the housing plate screws (6). Take care during assembly that the seal seat (11) does not contact the shaft (14) and become chipped. Ensure that the shaft guard (15) (where fitted) is in position.
- 2) Fit the mechanical seal (9).
  - a) Consider fitting a new seal.
  - b) Ensure all components are clean.
  - c) When fitting the seal seat, ensure that it is at right angles to the axis of the shaft and that the lapped sealing surface will face **towards** the mechanical seal assembly.
  - d) Take care during assembly that the seal seat does not contact the shaft and become chipped.
  - e) Ensure that the rubber or PTFE components are not cut or damaged during assembly. Any sharp edges on the shaft shoulder or keyway should be removed.
  - f) Seals may be fitted with a very slight smear of diluted soft soap solution. **Never use mineral oil, grease, vaseline**, etc, as it is **not** hygienic and may degrade the rubber.
  - g) When pegged seats are fitted, ensure that the hole or notch in the seat is lined up with the peg which protrudes from the seal seat housing. Failure to do so will result in seal failure.
- 3) Replace the key (21) in the pump stub shaft (14).
- 4) Slide the impeller back plate (19) (where fitted) and the impeller vane plate (20) onto the pump stub shaft (14).
- 5) Screw on the impeller locknut (22) (right hand thread) and finally tighten to the specified torque (see table right).
- 6) Refit the cover (18).
- 7) Fit the clamp ring (7) into position and tighten the clamp ring handle(s) (8), ensuring that the clamp ring is correctly located.

Typical pump with single internal seal

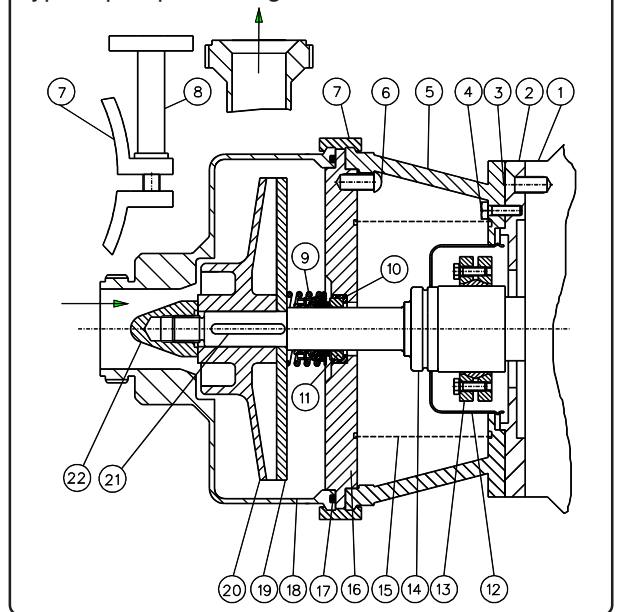

Pump model	Locknut torque (Nm)
D2/D2X	35
D2W	75
D3 & D4	90
D4A, D5, D6	130
D5A & D6A	180

- 8) Connect the inlet, outlet and flush (where fitted) connections.
- 9) Before start-up, the pump should be flooded with liquid at the seal faces as dry running will cause overheating and may damage the mating surfaces.

### MDM PUMPS LTD

Spring Lane  
Malvern  
Worcs WR14 1BP  
England

Tel: +44 (0)1684 892678  
Fax: +44 (0)1684 892841  
E-mail: sales@mdmpumps.co.uk  
www.mdmpumps.co.uk