



H pump range - replacing the seal:

double face to face seals, type 2100 or 2 (inboard) & 2100 or RB05 (outboard)

S1
h8

Dismantling the Pump



Pumps which convey hazardous liquids must be decontaminated before dismantling the pump. The appropriate personal protection equipment should be used.

Tools required: Torque wrench with socket - across flats 28mm (M16 locknut), 34mm (M24 locknut), 46mm (M36 locknut), Engineers pliers, Hide mallet.



1) Isolate the motor (1) from the power supply.

2) Disconnect the inlet and outlet connections.



Risk of contact with liquid being pumped.

3) Unscrew the clamp ring handle(s) (8) by several turns and lift the clamp ring (7) over the flanged adaptor (5).

4) Remove the cover (18).

5) Unscrew the impeller locknut (22) with the spanner (right hand thread).

6) Slide the impeller vane plate (20) and (where fitted) the back plate (19) forward off the shaft (14) by maintaining an even pressure. Hitting the impeller can cause serious damage.

7) Remove the key (21) from the pump stub shaft (14).

8) The inboard mechanical seal (9) is now accessible. Clean the shaft and slide the seal forwards off the shaft.

9) The face of the seal is now exposed and can be inspected.

10) To remove the seal seat assemblies (10,11) & (26,27), unscrew the flush connectors (23). Unscrew the housing plate screws (6) (where fitted) and take out the housing plate (16). The seal seats (11, 26) and seat rings (10,27) can all be inspected.

11) The outboard mechanical seal (25) is now accessible. Clean the shaft and slide the seal forwards off the shaft.

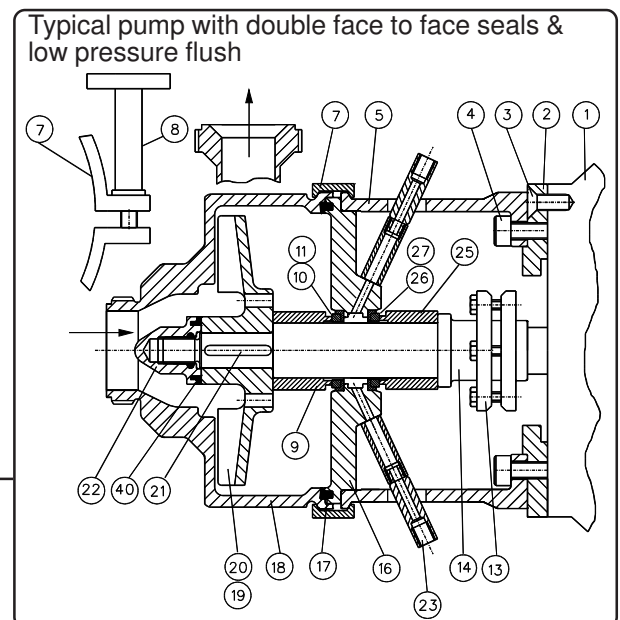

Reassembling the Pump

1) Push the outboard mechanical seal (25) fully onto the shaft (14) ensuring that the carbon face is towards the impeller end (see page S2).

2) Locate the inboard and outboard seal seat assemblies (10,11) & (26,27) in the housing plate (16). Fit the housing plate into the flanged adaptor (5) and tighten the housing plate screws (6) (where fitted). The outboard seal (25) will be squeezed to its working length. Take care during assembly that the seal seats (11,26) do not contact the shaft (14) and become chipped.

3) Screw in the flush connectors (23), and fit the inboard mechanical seal (9) (see page S2).

4) Refit the key (21) into the pump stub shaft (14).

5) Slide the impeller back plate (19) (where fitted) and the vane plate (20) onto the shaft.

6) Screw on the impeller locknut (22) (right hand

Pump model	Locknut torque (Nm)
H & CH	90 (M16 locknut)
	140 (M24 locknut)
	180 (M36 locknut)

thread) and finally tighten to the specified torque (see table).

7) Refit the cover (18).

8) Fit the clamp ring (7) into position and tighten the clamp ring handle (8), ensuring that the clamp ring is correctly located.

9) Connect the inlet, outlet and flush connections.

10) Before start-up, the flush must be running and the pump should be flooded with liquid at the seal faces, as dry running will cause overheating and may damage the mating surfaces.

Replacing the Seal - Double face to face seals, type 2100 or 2 (inboard) & 2100 or RB05 (outboard)

ATTENTION

Mechanical seals are precision products. Installation should be carried out to the laid down procedure. Seals should be installed in a clean environment with particular care given to the lapped and polished seal faces.

Notes: - For information on the seal fitted in your pump, please refer to the data sheet.

Tools required: Diluted soft soap solution, Seal fitting tube and sleeve (recommended).

Removing the old seals:

Dismantle the pump and seals as described on page S1.

Fitting the new seals:

- 1) Ensure all components are clean. Any sharp edges on the shaft shoulder or keyway should be removed.

Outboard seal type 2100 or RB05:

- 2) Push the outboard mechanical seal (4) fully onto the shaft (5) ensuring that the carbon face is towards the impeller end.
- 3) Ensure that the rubber bellows in the mechanical seal (4) are not cut or damaged during assembly.
- 4) Lubricate the inside sleeve of the bellows with a very slight smear of diluted soft soap solution. **Never use mineral oil, grease, vaseline**, etc, as it is **not** hygienic and may degrade the rubber.
- 5) Fit the seat (2) into the seat ring (3) to form the outboard seat assembly.
- 6) Press the outboard seat assembly fully down into the recess in the clamp plate (1), ensuring that it is at right angles to the axis of the shaft with the lapped sealing surface facing **towards** the outboard mechanical seal assembly (4).

Inboard seal type 2100 or 2:

- 7) Fit the seat (2) into the seat ring (3) to form the inboard seat assembly.
- 8) Press the inboard seat assembly fully down into the recess in the housing plate (1). Ensure that it is at right angles to the axis of the shaft and that the lapped sealing surface will face **towards** the inboard mechanical seal assembly.
- 9) Fit the housing plate (1) into the flanged adaptor and tighten the housing plate screws (where applicable). Take care during assembly that the seal seat does not contact the shaft and become chipped. Ensure that the shaft guard (where supplied) is in position.
- 10) Ensure that the rubber bellows (4) are not cut or damaged during assembly.

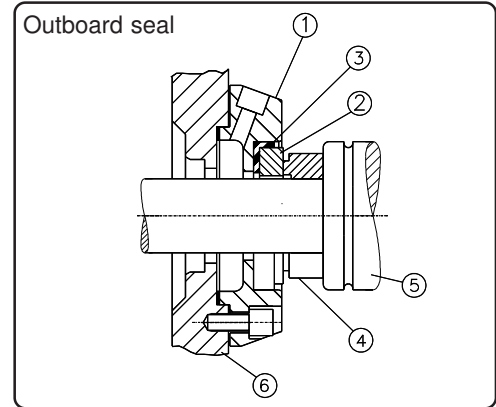

- 11) Lubricate the inside sleeve of the bellows with a very slight smear of diluted soft soap solution. **Never use mineral oil, grease, vaseline**, etc, as it is **not** hygienic and may degrade the rubber.
- 12) Ensure that the seal face (5) is inserted with the raised face outwards, ie the lapped surface is facing towards the seat (2).
- 13) Slide the seal unit onto the shaft until it makes contact with the seat (2), making sure that the bellows (4) is fully compressed. (*For the type 2, a seal fitting tube (6) is recommended for this operation.*)
- 14) *For type 2 only:* the driving dogs (7) of the drive ring are to be correctly engaged in the slots of the drive sleeve.
- 15) Reassemble the pump as described on page S1.
- 16) Before start-up, the flush must be running and the pump should be flooded with liquid at the seal faces, as dry running will cause overheating and may damage the mating surfaces.

